

Aluminum body, compact design hydraulic cylinders in pursuit of cost performance

- Wide selection of models is available with cylinder bores from 20 mm to 100 mm.
- Light-weight, compact design hydraulic cylinders with bodies constructed of special aluminum alloy.
- Cost-effective selection is available based on frequency of operation and working pressure.
- Operates at up to 16 MPa depending on the frequency of pressure supply.
- Special copper alloy bearings are adopted to improve wear resistance.



Standard Specifications

Type	General purpose type	Cutting oil proof type
Nominal pressure	10 MPa	
Maximum allowable pressure	16 MPa (Refer to the working pressure range diagram.)	
Proof test pressure	20 MPa	
Minimum operating pressure	0.3 MPa	
Working speed range	8 to 100mm/s	
Working temperature range (ambient temp. and oil temp.)	Standard type -10 to +70°C Switch Set AX/AZ type, T type -10 to +70°C WR/WS type -10 to +60°C (No freezing)	
Structure of cushioning	None	
Adaptable fluid	Petroleum-based fluid (When using another fluid, refer to the table of fluid adaptability.)	
Tolerance for thread	JIS 6H/6g	
Tolerance of stroke	0 to 0.8mm	
Mounting style	SD, LD, FA, FB	
Rod end threads	Female thread and male thread	
Applicable sensor for Switch Set	(φ20, φ25) T type 100S-1R: (φ32 to φ100) AX/AZ type WR/WS type	100SW-1R:WR/WS type

Working Pressure Range Diagram

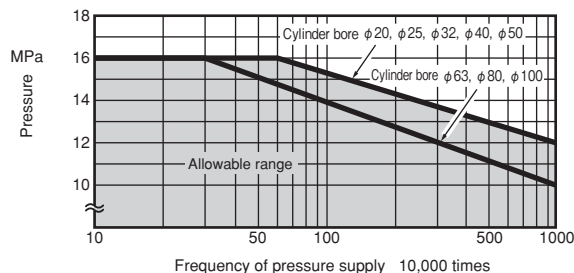

Terminologies

Nominal pressure

Pressure given to a cylinder for convenience of naming. It is not always the same as the working pressure (rated pressure) that guarantees performance under the specified conditions.

Maximum allowable pressure

Maximum allowable pressure generated in a cylinder (surge pressure, etc.).

Proof test pressure

Test pressure against which a cylinder can withstand without unreliable performance at the return to nominal pressure.

Minimum operating pressure

Minimum pressure at which cylinder installed horizontally operates under no load.

- Notes) • This series of cylinders does not have air vents.
• Since side load (eccentric load) must not be applied to the piston rod, take care when installing the cylinder.

For the details of the working pressure range diagram, refer to the information page of 100S-1 Series.

Product Lineup

Unit: mm

Series Variations	Type	Mounting style	φ20	φ25	φ32	φ40	φ50	φ63	φ80	φ100		
General purpose type	Double acting single rod	Standard type	100S-1	SD	LD·FA·FB	●	●	●	●	●	●	
		Switch Set	100S-1R	SD	LD·FA·FB	●	●	●	●	●	●	
	Double acting double rod	Standard type	100S-1D	SD	LD·FA	●	●	●	●	●	●	
		Switch Set	100S-1RD	SD	LD·FA	●	●	●	●	●	●	
	Cutting oil proof type	Double acting single rod	Standard type	100SW-1	SD	LD·FA·FB	●	●	●	●	●	●
			Switch Set	100SW-1R	SD	LD·FA·FB	●	●	●	●	●	●
Double acting double rod		Standard type	100SW-1D	SD	LD·FA	●	●	●	●	●	●	
		Switch Set	100SW-1RD	SD	LD·FA	●	●	●	●	●	●	

- Notes) • When using a sensor, use a Switch Set Cylinder.
• No sensor can be mounted onto the standard type cylinder.

Double acting single rod



Standard type (100S-1·100SW-1)



Switch Set (100S-1R·100SW-1R)

Double acting double rod



Standard type (100S-1D·100SW-1D)



Switch Set (100S-1RD·100SW-1RD)

- The general purpose type and cutting oil proof type have the same dimensions.

Cutting oil proof type

- This type of cylinders can be used in a place where they are exposed to cutting oil (coolant) for machine tools.
- The adaptability of seal materials to cutting oil is shown right.

Adaptability of Seal Material (HNBR) to Cutting oil

Nonaqueous cutting oil		Aqueous cutting oil
Type 1	Type 2	
○	×	○

○ : Applicable × : Inapplicable

How to order

General Purpose Type (Bore ϕ 20 to ϕ 100)

The item enclosed by broken line needs not to be entered, if unnecessary. Semi-standard specification

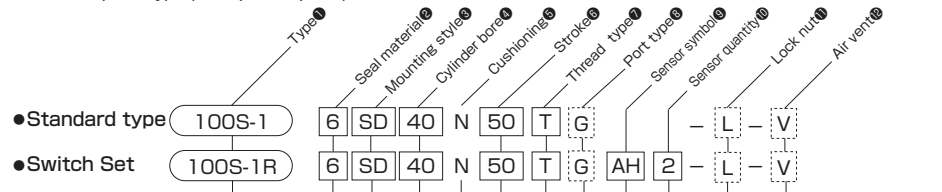

- Standard type: 100S-1
 - Switch Set: 100S-1R
- Double acting single rod
100S-1 : Standard type
100S-1R : Switch Set
- Double acting double rod
100S-1D : Standard type
100S-1RD : Switch Set

- 3 Fluorocarbon
- 6 HNBR

Note) The seal of cylinders with bores of 20 and 25 mm is only HNBR.

- SD SD style (basic style)
- LD LD style (end angles)
- FA FA style (rod flange)
- FB FB style (cap flange)

Note) When ordering the mounting style LD or FA cylinder, it is necessary to change dimension WF of the SD style. For details, contact us.

Cylinder bore (mm)
 ϕ 20 to ϕ 100

No cushion

Cylinder stroke (mm)

Note) When the sensor is retrofitted to the standard type, it does not work.

Adaptability of Fluid to Seal Material

Seal material	Adaptable fluid				
	Petroleum-based fluid	Water-glycol fluid	Phosphate ester fluid	Water in oil fluid	Oil in water fluid
3 Fluorocarbon	○	×	○	○	○
6 HNBR	○	○	×	○	○

Notes) 1. ○ : Applicable × : Inapplicable
2. The ○-marked items are recommended seal materials in case of giving the first priority to abrasion resistance.

Specification of air vent (order made)

The air vents are laid on the port surface and located symmetrical positions to the ports.

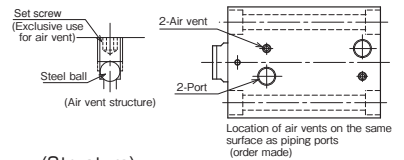

(Structure)
Applicable to : Single rod, double rod
SD/LD/FA/FB style
Bore ϕ 32 to ϕ 100

- None Rc thread
- G G thread

Note) G thread is applicable only to the SD style.

 Female thread type (No entry for standard type)

T Male thread type (Semi-standard)

Note) In case of double acting double rod type, both sides are male thread type.

- None No air vent (standard)
- V With air vent (order made: ϕ 32 to ϕ 100)

L With one lock nut

Notes) Available only for male thread type. Additional order is required when 2 or more lock nuts are necessary.

Sensor quantity (1 or 2)

Sensor symbol
Note) Select applicable sensors out of the Sensor List.

Notes on ordering Switch Set

- When no sensor is required, specify 0 for the sensor symbol **①** and the sensor quantity **②**.
- Sensors are not mounted on cylinders at delivery.

How to order

Cutting Oil Proof Type (Bore ϕ 32 to ϕ 100)

The item enclosed by broken line needs not to be entered, if unnecessary.

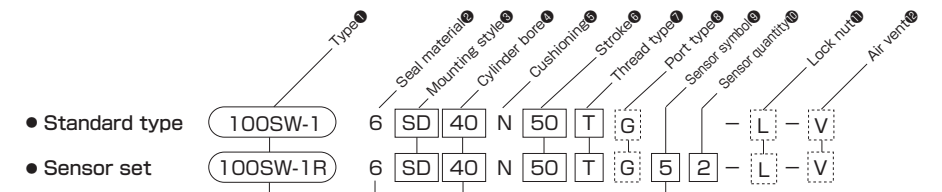

- Standard type: 100SW-1
 - Sensor set: 100SW-1R
- Double acting single rod
100SW-1 : Standard type
100SW-1R : Switch Set
- Double acting double rod
100SW-1D : Standard type
100SW-1RD : Switch Set

- 6 HNBR

Cylinder bore (mm)
 ϕ 32 to ϕ 100

Note) Bore size 20 mm and 25 mm are not available.

- 5 WR525 (rear wiring, w/5 m cord)
- 8 WR535 (upper wiring, w/5 m cord)
- 5F WR525F (rear wiring, w/5 m cord/flexible tube attached)
- 8F WR535F (upper wiring, w/5 m cord/flexible tube attached)
- RA AX205WCE (rear wiring, w/5 m cord)
- RB AZ205WCE (upper wiring, w/5 m cord)
- 2 WS235-1 (rear wiring, w/5 m cord)
- 1 WS245-1 (upper wiring, w/5 m cord)
- 2F WS235-1F (rear wiring, w/5 m cord/flexible tube attached)
- 1F WS245-1F (upper wiring, w/5 m cord/flexible tube attached)

Note) For the details of types other than the above, refer to the general purpose type.

Note) For the details of types other than the above, refer to the general purpose type.

Cutting Oil Proof Type: Adaptability of cutting oil to seal material

Seal material	Nonaqueous cutting oil		Aqueous cutting oil
	Type 1	Type 2	
6 HNBR	○	×	○

Note) ○ : Applicable × : Inapplicable

Port G thread type (only for SD style)

- Please specify the code as following.
- (Example) 100S-1 6SD63N30-G
Port G thread type

Note) ● The port G thread has dimensions different from the standard dimensions depending on the bore. Refer to the dimensional tables.

Lock nut number for ordering

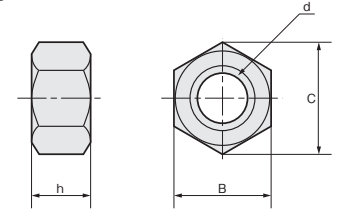

Dimensional Table

Bore	Part number	d	B	C	h
ϕ 20	LNH-10F-H	M10×1.25	17	19.6	6
ϕ 25	LNH-12F-H	M12×1.25	19	21.9	7
ϕ 32	LNH-16F-H	M16×1.5	22	25.4	10
ϕ 40	LNH-20F-H	M20×1.5	27	31.2	12
ϕ 50	LNH-24F-H	M24×1.5	32	37.0	14
ϕ 63	LNH-30F-H	M30×1.5	41	47.3	17
ϕ 80	LNH-39F-H	M39×1.5	55	63.5	20
ϕ 100	LNH-48F-H	M48×1.5	70	80.8	26

Sensor List (Bore $\phi 20$ and $\phi 25$)

Type	Sensor symbol	Load voltage range	Load current range	Max. switching capacity	Protective circuit	Indicating lamp	Wiring method	Cord length	Applicable load	
Reed sensor	UA TOH	DC:12 · 24V	DC : 5 to 50mA	DC : 1.2W AC : 2VA	None	LED	0.2 mm ² , 2-core, outer dia. $\phi 3.4$ mm Rear wiring	1 m	Small relay, programmable controller	
	UB TOH3	AC:100V	AC : 7 to 20mA			3 m				
	UC T5H	DC:5 · 12 · 24V	DC: 50 mA or less			1 m				
	UD T5H3	AC:100V	AC: 20 mA or less			3 m				
	UE TOV	DC:12 · 24V	DC : 5 to 50mA			1 m				
	UF TOV3	AC:100V	AC : 7 to 20mA			3 m				
	UG T5V	DC:5 · 12 · 24V	DC: 50 mA or less			1 m				
	UH T5V3	AC:100V	AC: 20 mA or less			3 m				
Solid state sensor	UJ T2H	DC:10 to 30V	5 to 20 mA	—	Provided	LED	0.2 mm ² , 2-core, outer dia. $\phi 3.4$ mm Rear wiring	1 m	Small relay, programmable controller	
	UK T2H3					3 m				
	UL T2YH					1 m				
	UM T2YH3					3 m				
	UN T3H	DC:30 V or less	100 mA or less	Power supply voltage 10 to 30 V DC		LED		0.2 mm ² , 2-core, outer dia. $\phi 3.4$ mm Rear wiring		1 m
	UP T3H3					3 m				
	UQ T2V					1 m				
	UR T2V3					3 m				
	US T2YV	DC:10 to 30V	5 to 20 mA	—		LED		0.3 mm ² , 2-core, outer dia. $\phi 4.8$ mm Rear wiring		1 m
	UT T2YV3					3 m				
	UU T3V					1 m				
	UV T3V3					3 m				

Notes) ● For the sensors without a protective circuit, be sure to provide a protective circuit (SK-100) with the load when using any induction load (relay, etc.).
 ● For the details of sensors, be sure to read the sensor specifications at the end of this catalog.
 ● We recommend AND Unit (AU series) for multiple sensors connected in series.
 For details, refer to AND Unit at the end of this catalog.

● General purpose type One-LED type



Two-LED type



Sensor Mountable Minimum Stroke

Bore	With one sensor				With two sensors			
	AX/AZ type	T type	WR type	WS type	AX/AZ type	T type	WR type	WS type
$\phi 20$	—	5	—	—	—	10	—	—
$\phi 25$	—	5	—	—	—	10	—	—
$\phi 32$	—	—	—	—	—	—	—	—
$\phi 40$	5	—	5	10	10*	—	10	20
$\phi 50$	5	—	5	10	10*	—	10	20
$\phi 63$	5	—	5	10	10*	—	10	20
$\phi 80$	5	—	5	10	10*	—	10	20
$\phi 100$	5	—	5	10	10*	—	10	15

Notes) ● When using two sensors of the WR or WS type, they cannot be mounted on the same surface.
 ● When two reed sensors are used on one surface at a stroke of 10 mm, adjust their positions because the sensors may interfere with each other.
 * If you want to mount AX or AZ type solid state sensors to a 10 mm stroke cylinder, use two sensor mounting grooves.

■ Notes on ordering WR or WS type sensors

● When ordering the cutting oil proof type sensors, WR and WS types, please be carefully the following notification.

- 5 WR525
 - 8 WR535
 - 2 WS235-1
 - 1 WS245-1
- The sensor and straight box connector (F-SB) are combined (the flexible tube (F-0.5 : 4.8 m) is required).
- 5F WR525F
 - 8F WR535F
 - 2F WS235-1F
 - 1F WS245-1F
- The flexible tube (F-0.5 : 4.8 m) is attached to the sensor and straight box connector (F-SB).

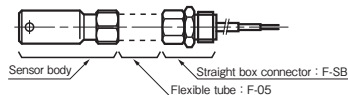

Sensor List (Bore $\phi 32$ to $\phi 100$)

Type	Sensor symbol	Load voltage range	Load current range	Max. switching capacity	Protective circuit	Indicating lamp	Wiring method	Cord length	Applicable load			
Reed sensor	AF AX101CE	DC:5 to 30V	DC:5 to 40mA	DC:1.5W AC:2VA	None	LED	0.3 mm ² , 2-core, outer dia. $\phi 4$ mm Rear wiring	1.5m	Small relay, programmable controller			
	AG AX105CE							5m				
	AH AX111CE							1.5m				
	AJ AX115CE							5m				
	AE AX125CE	DC: 30 V or less AC: 120 V or less	DC: 40 mA or less AC: 20 mA or less	2VA	Provided	None	None	5m				
	AK AX11ACE	AC:5 to 120V	5 to 20mA					4-pin connector type Rear wiring		0.5m		
	AL AX11BCE	DC:5 to 30V	5 to 40mA					1.5W		0.5m		
	5 WR525	DC:5 to 50V	DC:3 to 40mA					DC:1.5W AC:2VA		5m		
	5F WR525F	AC:5 to 120V	AC:3 to 20mA	DC:1.5W AC:2VA	None	LED	0.3 mm ² , 2-core, outer dia. $\phi 4$ mm Rear wiring	5m				
	AP AZ101CE	1.5m										
	AR AZ105CE	DC:5 to 30V	DC:5 to 40mA					5m				
	AS AZ111CE	AC:5 to 120V	AC:5 to 20mA					1.5m				
	AT AZ115CE	DC: 30 V or less AC: 120 V or less	DC: 40 mA or less AC: 20 mA or less	2VA	Provided	None	None	5m				
	AN AZ125CE							5m				
	AU AZ11ACE							AC:5 to 120V		5 to 20mA	4-pin connector type Upper wiring	0.5m
	AW AZ11BCE							DC:5 to 30V		5 to 40mA	1.5W	0.5m
AM AX135CE	AC/DC : 90 to 240V	5 to 300mA	B contact output	Provided	LED	0.3 mm ² , 2-core, outer dia. $\phi 4$ mm Upper wiring	5m					
AY AZ135CE							5m					
8 WR535							DC:5 to 50V	DC:3 to 40mA	DC:1.5W AC:2VA	5m		
8F WR535F							AC:5 to 120V	AC:3 to 20mA	DC:1.5W AC:2VA	None	LED	0.3 mm ² , 2-core, outer dia. $\phi 4$ mm Upper wiring
Solid state sensor	BE AX201CE-1	DC:5 to 30V	5 to 40mA	—	Provided	LED	0.3 mm ² , 2-core, outer dia. $\phi 4$ mm Rear wiring	1.5m				
	BF AX205CE-1							5m				
	CE AX211CE-1							1.5m				
	CF AX215CE-1							5m				
2 WS235-1	DC:10 to 30V	5 to 20mA	—	Provided	LED	0.3 mm ² , 2-core, outer dia. $\phi 4$ mm Rear wiring	5m					
2F WS235-1F							5m					
Cutting oil proof type	BM AZ201CE-1	DC:5 to 30V	5 to 40mA	—	Provided	LED	0.3 mm ² , 2-core, outer dia. $\phi 4$ mm Upper wiring	1.5m				
	BN AZ205CE-1							5m				
	CM AZ211CE-1							1.5m				
	CN AZ215CE-1							5m				
Solid state sensor	RA AX205WCE	DC:5 to 30V	5 to 40mA	—	Provided	LED	0.3 mm ² , 2-core, outer dia. $\phi 4$ mm Rear wiring	5m				
	RB AZ205WCE							5m				
	1 WS245-1	DC:10 to 30V	5 to 20mA	—	Provided	LED	0.3 mm ² , 2-core, outer dia. $\phi 4$ mm Upper wiring	5m				
	1F WS245-1F							5m				
	CT AX211CE-1	DC:5 to 30V	5 to 40mA	—	Provided	LED	0.3 mm ² , 2-core, outer dia. $\phi 4$ mm Rear wiring	1.5m				
	CU AX215CE-1							5m				
	CV AX21BCE-1							4-pin connector type Rear wiring	0.5m			
	CW AZ211CE-1							0.3 mm ² , 2-core, outer dia. $\phi 4$ mm Upper wiring	1.5m			
	CX AZ215CE-1							5m				
	CY AZ21BCE-1							4-pin connector type Upper wiring	0.5m			

Notes) ● For the sensors without a protective circuit, be sure to provide a protective circuit (SK-100) with the load when using any induction load (relay, etc.).
 ● The output logic of AX and AZ135CE is B contact. When the piston is detected, the sensor contact turns off (the lamp turns on).
 ● For the details of sensors, be sure to read the sensor specifications at the end of this catalog.
 ● WR and WS type sensors are cutting oil proof.
 ● We recommend AND Unit (AU series) for multiple sensors connected in series.
 For details, refer to AND Unit at the end of this catalog.

● Standard type

AX type (rear wiring) AZ type (upper wiring)



● Cutting oil proof type

WR/WS type sensors
 ●Rear wiring ●Upper wiring

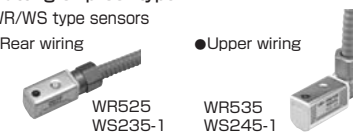

CAD/DATA is available.

SD

General purpose type 100S-1 6 SD Bore N Stroke T (φ20 to φ100)
Cutting oil proof type 100SW-1 6 SD Bore N Stroke T (φ32 to φ100)

• Bore φ20 and φ25

None : Female thread type
T : Male thread type

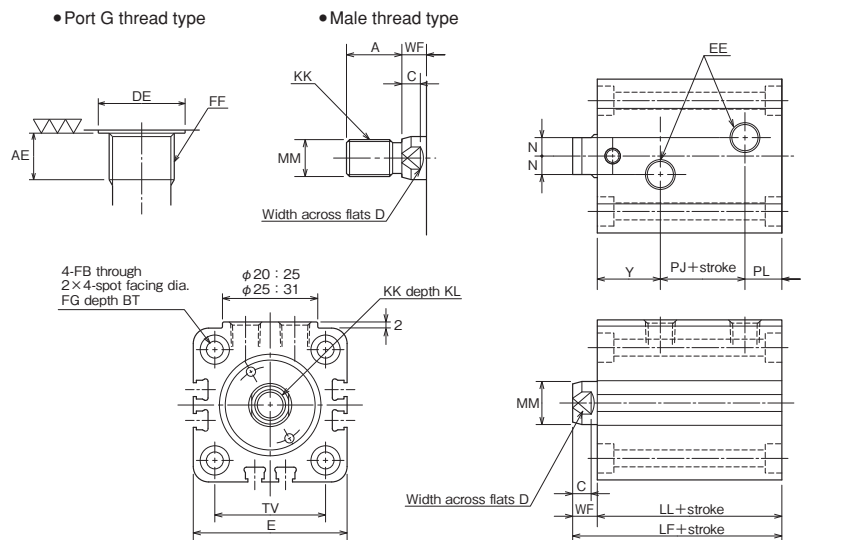

• Bore φ32 to φ100

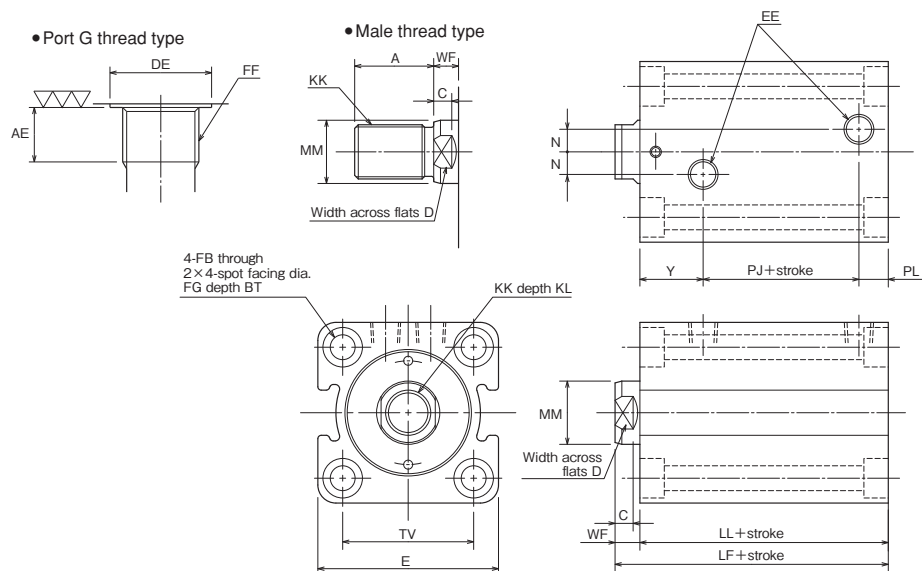

• For the mounting of sensors, refer to the "dimensional drawings of Switch Set". All the contents other than sensor mounting dimensions are the same.

Dimensional Table

Symbol Bore	A	AE	BT	C	D	DE	E	EE	FB	FF	FG	KK		KL
												Female thread type	Male thread type	
φ20	15(25)	8	5.4	6	10	φ17.2	□44	Rc1/8	φ5.5	G1/8	φ9.5	M8×1.25	M10×1.25	10
φ25	18(30)	8	5.4	6	12	φ17.2	□50	Rc1/8	φ5.5	G1/8	φ9.5	M10×1.5	M12×1.25	12
φ32	25(40)	8	6.5	7	14	φ17.2	□62	Rc1/4	φ6.6	G1/8	φ11	M12×1.75	M16×1.5	15
φ40	30(45)	8	8.6	7	19	φ17.2	□70	Rc1/4	φ9	G1/8	φ14	M16×2	M20×1.5	20
φ50	35(50)	12	10.8	8	24	φ21.5	□80	Rc1/4	φ11	G1/4	φ17.5	M20×2.5	M24×1.5	24
φ63	45(60)	12	13	9	30	φ21.5	□94	Rc1/4	φ14	G1/4	φ20	M27×3	M30×1.5	33
φ80	60(80)	12	15.2	14	41	φ21.5	□114	Rc3/8	φ16	G1/4	φ23	M30×3.5	M39×1.5	36
φ100	75(95)	12	17.5	22	50	φ25.5	□138	Rc3/8	φ18	G3/8	φ26	M39×4	M48×1.5	45

Symbol Bore	LF	LL	MM	N		PJ		PL		TV	WF	Y	
				Rc thread	G thread	Rc thread	G thread	Rc thread	G thread			Rc thread	G thread
φ20	51	43	φ12	3	3	14.5	14.5	10	10	□30	8	18.5	18.5
φ25	53	45	φ14	6	6	12.5	12.5	12	12	□36	8	20.5	20.5
φ32	64	54	φ18	10	10	14	14	12	12	□47	10	28	28
φ40	65	55	φ22	10	10	16	16	12	12	□52	10	27	27
φ50	71	60	φ28	10	14	19	13.5	13	18.5	□58	11	28	28
φ63	80	67	φ36	10	16	24	20	13	17	□69	13	30	30
φ80	95	78	φ45	15	19	25	24	18	18	□86	17	35	36
φ100	122	96	φ56	15	18	26	26	28	28	□106	26	42	42

Notes: • When the lock nut is used, the parenthesized dimension A is recommended. (Order made)
 • The lock nut needs to be ordered separately.
 • 20 mm and 25 mm bore cylinders with a stroke of 5 mm have the same body size as those with a stroke of 10 mm.
 • 20 mm and 25 mm bore sizes of the cutting oil proof type are not available.
 • The tolerance of MM is f8.

CAD/DATA is available.

LD

General purpose type 100S-1 6 LD Bore N Stroke T (φ20 to φ100)
Cutting oil proof type 100SW-1 6 LD Bore N Stroke T (φ32 to φ100)

None : Female thread type
T : Male thread type

● Bore φ20 and φ25

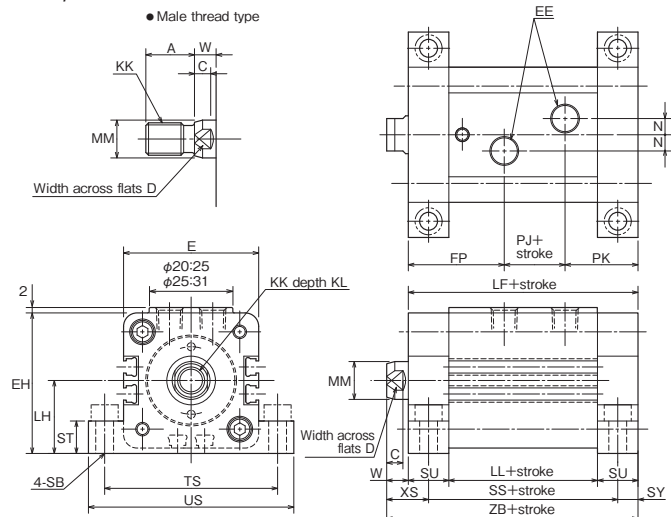

● Bore φ32 to φ100

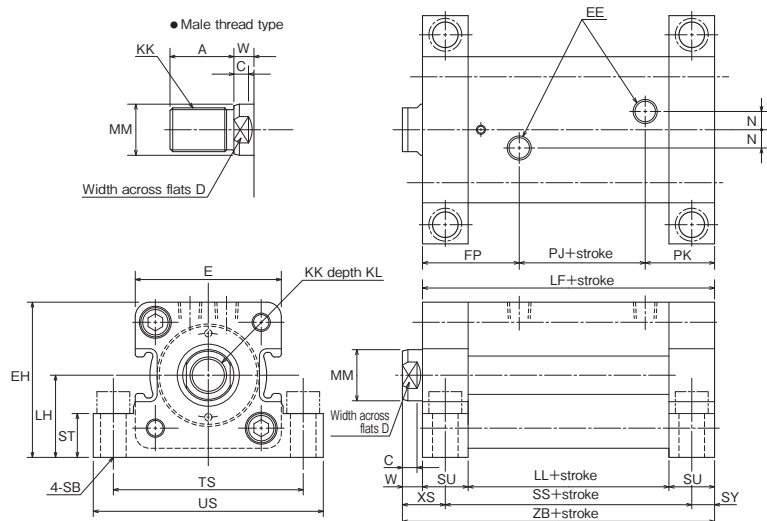

● For the mounting of sensors, refer to the "dimensional drawings of Switch Set".
All the contents other than sensor mounting dimensions are the same.
* When installing the cylinder on the grounding surface, be sure to use hex. socket head cap screws.

Dimensional Table

Symbol Bore	A	C	D	E	EE	EH	FP	KK		KL	LF	LH
								Female thread type	Male thread type			
φ20	15(25)	6	10	□44	Rc1/8	46	33.5	M8×1.25	M10×1.25	10	73	24±0.15
φ25	18(30)	6	12	□50	Rc1/8	52	35.5	M10×1.5	M12×1.25	12	75	27±0.15
φ32	25(40)	7	14	□62	Rc1/4	66	48	M12×1.75	M16×1.5	15	94	35±0.15
φ40	30(45)	7	19	□70	Rc1/4	72.5	47	M16×2	M20×1.5	20	95	37.5±0.15
φ50	35(50)	8	24	□80	Rc1/4	85	53	M20×2.5	M24×1.5	24	110	45±0.15
φ63	45(60)	9	30	□94	Rc1/4	97	55	M27×3	M30×1.5	33	117	50±0.15
φ80	60(80)	14	41	□114	Rc3/8	117	65	M30×3.5	M39×1.5	36	138	60±0.25
φ100	75(95)	22	50	□138	Rc3/8	140	77	M39×4	M48×1.5	45	166	71±0.25

Symbol Bore	LL	MM	N	PJ	PK	SB	SS	ST	SU	SY	TS	US	W	XS	ZB
φ20	43	φ12	3	14.5	25	6.6	58	12	15	7.5	58	70	8	15.5	81
φ25	45	φ14	6	12.5	27	6.6	60	12	15	7.5	64	76	8	15.5	83
φ32	54	φ18	10	14	32	9	74	16	20	10	79	94	10	20	104
φ40	55	φ22	10	16	32	11	75	20	20	10	90	108	10	20	105
φ50	60	φ28	10	19	38	14	85	24	25	12.5	104	126	11	23.5	121
φ63	67	φ36	10	24	38	16	92	30	25	12.5	121	146	13	25.5	130
φ80	78	φ45	15	25	48	18	108	35	30	15	144	172	17	32	155
φ100	96	φ56	15	26	63	22	131	43	35	17.5	174	208	26	43.5	192

Notes) ● When the lock nut is used, the parenthesized dimension A is recommended. (Order made)
● The lock nut needs to be ordered separately.
● 20 mm and 25 mm bore cylinders with a stroke of 5 mm have the same body size as those with a stroke of 10 mm.
● 20 mm and 25 mm bore sizes of the cutting oil proof type are not available.
● The tolerance of MM is f8.

CAD/DATA is available.

FA

General purpose type 100S-1 6 FA Bore N Stroke T ($\phi 20$ to $\phi 100$)
Cutting oil proof type 100SW-1 6 FA Bore N Stroke T ($\phi 32$ to $\phi 100$)

None : Female thread type
T : Male thread type

- Bore $\phi 20$ and $\phi 25$

• Male thread type

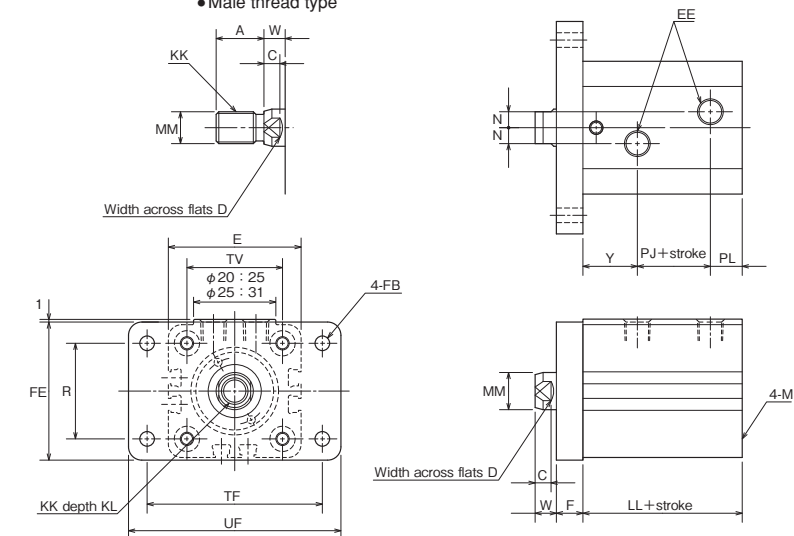

- Bore $\phi 32$ to $\phi 100$

• Male thread type

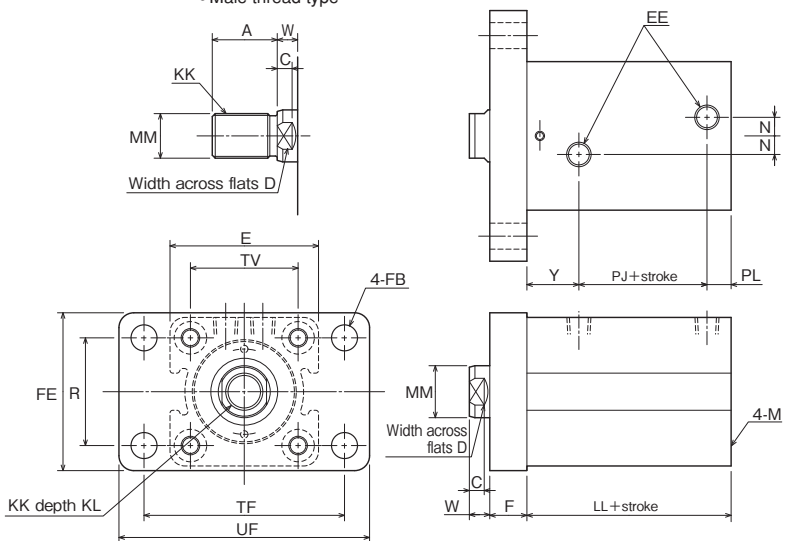

- For the mounting of sensors, refer to the "dimensional drawings of Switch Set". All the contents other than sensor mounting dimensions are the same.

Dimensional Table

Symbol Bore	A	C	D	E	EE	F	FB	FE	KK		KL	LL
									Female thread type	Male thread type		
$\phi 20$	15(25)	6	10	$\square 44$	Rc1/8	10	$\phi 5.5$	46	M8×1.25	M10×1.25	10	43
$\phi 25$	18(30)	6	12	$\square 50$	Rc1/8	10	$\phi 5.5$	52	M10×1.5	M12×1.25	12	45
$\phi 32$	25(40)	7	14	$\square 62$	Rc1/4	15	$\phi 6.6$	62	M12×1.75	M16×1.5	15	54
$\phi 40$	30(45)	7	19	$\square 70$	Rc1/4	20	$\phi 11$	70	M16×2	M20×1.5	20	55
$\phi 50$	35(50)	8	24	$\square 80$	Rc1/4	20	$\phi 14$	85	M20×2.5	M24×1.5	24	60
$\phi 63$	45(60)	9	30	$\square 94$	Rc1/4	20	$\phi 14$	98	M27×3	M30×1.5	33	67
$\phi 80$	60(80)	14	41	$\square 114$	Rc3/8	25	$\phi 18$	118	M30×3.5	M39×1.5	36	78
$\phi 100$	75(95)	22	50	$\square 138$	Rc3/8	30	$\phi 22$	150	M39×4	M48×1.5	45	96

Symbol Bore	M	MM	N	PJ	PL	R	TF	TV	UF	W	Y
$\phi 20$	M5×0.8	$\phi 12$	3	14.5	10	30	60	$\square 30$	75	8	18.5
$\phi 25$	M5×0.8	$\phi 14$	6	12.5	12	36	66	$\square 36$	80	8	20.5
$\phi 32$	M6×1	$\phi 18$	10	14	12	40	80	$\square 47$	95	10	28
$\phi 40$	M8×1.25	$\phi 22$	10	16	12	46	96	$\square 52$	118	10	27
$\phi 50$	M10×1.5	$\phi 28$	10	19	13	58	108	$\square 58$	135	11	28
$\phi 63$	M12×1.75	$\phi 36$	10	24	13	65	124	$\square 69$	150	13	30
$\phi 80$	M14×2	$\phi 45$	15	25	18	87	154	$\square 86$	185	17	35
$\phi 100$	M16×2	$\phi 56$	15	26	28	109	190	$\square 106$	230	26	42

- Notes) ● When the lock nut is used, the parenthesized dimension A is recommended. (Order made)
 ● The lock nut needs to be ordered separately.
 ● 20 mm and 25 mm bore cylinders with a stroke of 5 mm have the same body size as those with a stroke of 10 mm.
 ● 20 mm and 25 mm bore sizes of the cutting oil proof type are not available.
 ● The tolerance of MM is f8.

CAD/DATA is available.

FB

General purpose type 100S-1 6 FB Bore N Stroke T ($\phi 20$ to $\phi 100$)
 Cutting oil proof type 100SW-1 6 FB Bore N Stroke T ($\phi 32$ to $\phi 100$)

None : Female thread type
 : Male thread type

- Bore $\phi 20$ and $\phi 25$

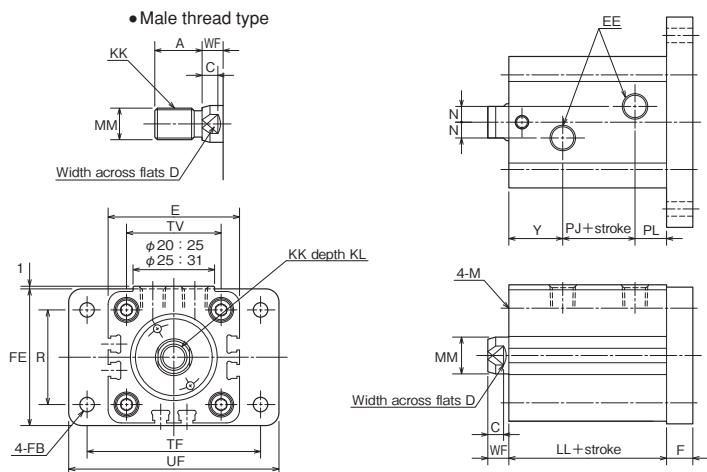

- Bore $\phi 32$ to $\phi 100$

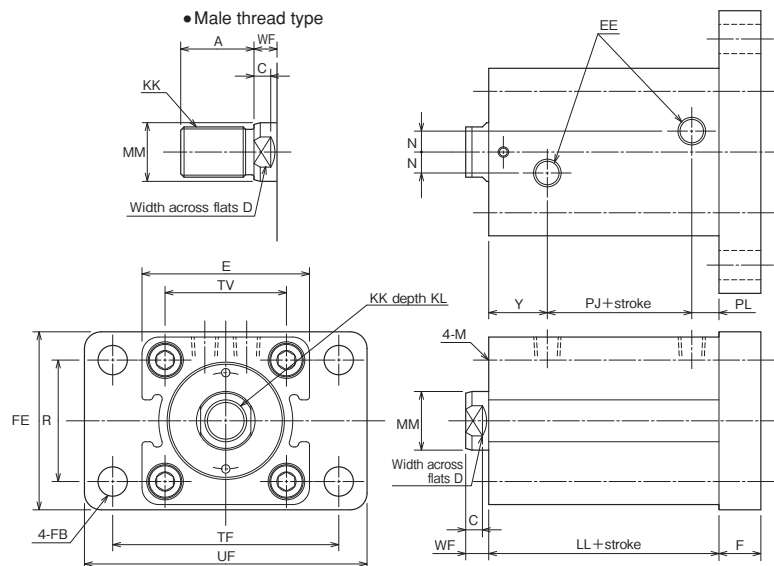

- For the mounting of sensors, refer to the "dimensional drawings of Switch Set". All the contents other than sensor mounting dimensions are the same.

Dimensional Table

Symbol Bore	A	C	D	E	EE	F	FB	FE	KK		KL	LL
									Female thread type	Male thread type		
$\phi 20$	15(25)	6	10	$\square 44$	Rc1/8	10	$\phi 5.5$	46	M8×1.25	M10×1.25	10	43
$\phi 25$	18(30)	6	12	$\square 50$	Rc1/8	10	$\phi 5.5$	52	M10×1.5	M12×1.25	12	45
$\phi 32$	25(40)	7	14	$\square 62$	Rc1/4	15	$\phi 6.6$	62	M12×1.75	M16×1.5	15	54
$\phi 40$	30(45)	7	19	$\square 70$	Rc1/4	20	$\phi 11$	70	M16×2	M20×1.5	20	55
$\phi 50$	35(50)	8	24	$\square 80$	Rc1/4	20	$\phi 14$	85	M20×2.5	M24×1.5	24	60
$\phi 63$	45(60)	9	30	$\square 94$	Rc1/4	20	$\phi 14$	98	M27×3	M30×1.5	33	67
$\phi 80$	60(80)	14	41	$\square 114$	Rc3/8	25	$\phi 18$	118	M30×3.5	M39×1.5	36	78
$\phi 100$	75(95)	22	50	$\square 138$	Rc3/8	30	$\phi 22$	150	M39×4	M48×1.5	45	96

Symbol Bore	M	MM	N	PJ	PL	R	TF	TV	UF	WF	Y
$\phi 20$	M5×0.8	$\phi 12$	3	14.2	10	30	60	$\square 30$	75	8	18.5
$\phi 25$	M5×0.8	$\phi 14$	6	12.5	12	36	66	$\square 36$	80	8	20.5
$\phi 32$	M6×1	$\phi 18$	10	14	12	40	80	$\square 47$	95	10	28
$\phi 40$	M8×1.25	$\phi 22$	10	16	12	46	96	$\square 52$	118	10	27
$\phi 50$	M10×1.5	$\phi 28$	10	19	13	58	108	$\square 58$	135	11	28
$\phi 63$	M12×1.75	$\phi 36$	10	24	13	65	124	$\square 69$	150	13	30
$\phi 80$	M14×2	$\phi 45$	15	25	18	87	154	$\square 86$	185	17	35
$\phi 100$	M16×2	$\phi 56$	15	26	28	109	190	$\square 106$	230	26	42

- Notes) ● When the lock nut is used, the parenthesized dimension A is recommended. (Order made)
 ● The lock nut needs to be ordered separately.
 ● 20 mm and 25 mm bore cylinders with a stroke of 5 mm have the same body size as those with a stroke of 10 mm.
 ● 20 mm and 25 mm bore sizes of the cutting oil proof type are not available.
 ● The tolerance of MM is f8.

CAD/DATA is available.

SD

General purpose type 100S-1D 6 SD Bore N Stroke T ($\phi 20$ to $\phi 100$)
 Cutting oil proof type 100SW-1D 6 SD Bore N Stroke T ($\phi 32$ to $\phi 100$)

None : Female thread type
 T : Male thread type

- Bore $\phi 20$ and $\phi 25$
- Port G thread type

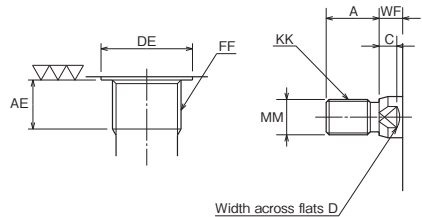

- Male thread type

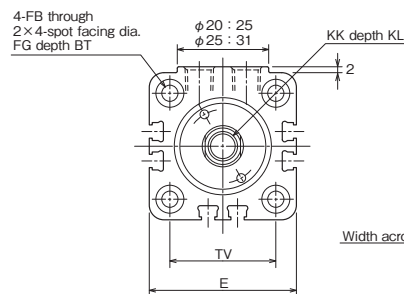
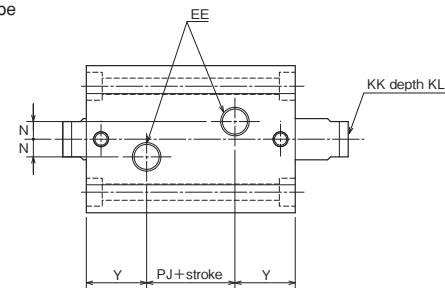

- Bore $\phi 32$ to $\phi 100$
- Port G thread type

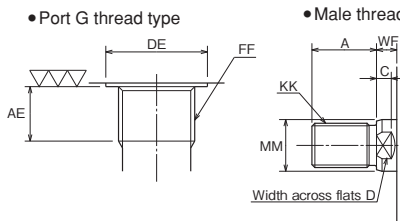

- Male thread type

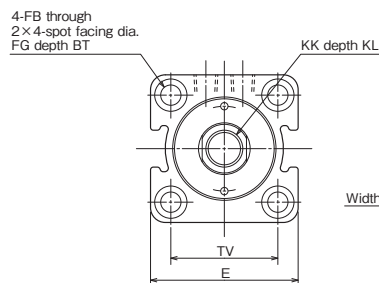
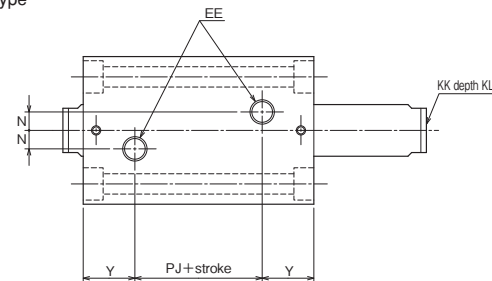

- The surface without V-shaped round grooves on the end face is the mounting surface.
- For the mounting of sensors, refer to the "dimensional drawings of Switch Set".
All the contents other than sensor mounting dimensions are the same.

Dimensional Table

Symbol Bore	A	AE	BT	C	D	DE	E	EE	FB	FF	FG	KK		KL
												Female thread type	Male thread type	
$\phi 20$	15(25)	8	5.4	6	10	$\phi 17.2$	$\square 44$	Rc1/8	$\phi 5.5$	G1/8	$\phi 9.5$	M8x1.25	M10x1.25	10
$\phi 25$	18(30)	8	5.4	6	12	$\phi 17.2$	$\square 50$	Rc1/8	$\phi 5.5$	G1/8	$\phi 9.5$	M10x1.5	M12x1.25	12
$\phi 32$	25(40)	8	6.5	7	14	$\phi 17.2$	$\square 62$	Rc1/4	$\phi 6.6$	G1/8	$\phi 11$	M12x1.75	M16x1.5	15
$\phi 40$	30(45)	8	8.6	7	19	$\phi 17.2$	$\square 70$	Rc1/4	$\phi 9$	G1/8	$\phi 14$	M16x2	M20x1.5	20
$\phi 50$	35(50)	12	10.8	8	24	$\phi 21.5$	$\square 80$	Rc1/4	$\phi 11$	G1/4	$\phi 17.5$	M20x2.5	M24x1.5	24
$\phi 63$	45(60)	12	13	9	30	$\phi 21.5$	$\square 94$	Rc1/4	$\phi 14$	G1/4	$\phi 20$	M27x3	M30x1.5	33
$\phi 80$	60(80)	12	15.2	14	41	$\phi 21.5$	$\square 114$	Rc3/8	$\phi 16$	G1/4	$\phi 23$	M30x3.5	M39x1.5	36
$\phi 100$	75(95)	12	17.5	22	50	$\phi 25.5$	$\square 138$	Rc3/8	$\phi 18$	G3/8	$\phi 26$	M39x4	M48x1.5	45

Symbol Bore	LL	MM	N		PJ		TV	WF	Y	
			Rc thread	G thread	Rc thread	G thread			Rc thread	G thread
$\phi 20$	54	$\phi 12$	3	3	17	17	$\square 30$	8	18.5	18.5
$\phi 25$	56	$\phi 14$	6	6	15	15	$\square 36$	8	20.5	20.5
$\phi 32$	72	$\phi 18$	10	10	16	16	$\square 47$	10	28	28
$\phi 40$	72	$\phi 22$	10	10	18	18	$\square 52$	10	27	27
$\phi 50$	75	$\phi 28$	10	14	19	19	$\square 58$	11	28	28
$\phi 63$	82	$\phi 36$	10	16	22	22	$\square 69$	13	30	30
$\phi 80$	95	$\phi 45$	15	19	25	23	$\square 86$	17	35	36
$\phi 100$	108	$\phi 56$	15	18	24	24	$\square 106$	26	42	42

- (Notes)
- When the lock nut is used, the parenthesized dimension A is recommended. (Order made)
 - The lock nut needs to be ordered separately.
 - 20 mm and 25 mm bore cylinders with a stroke of 5 mm have the same body size as those with a stroke of 10 mm.
 - 20 mm and 25 mm bore sizes of the cutting oil proof type are not available.
 - The tolerance of MM is f8.

CAD/DATA is available.

LD

General purpose type 100S-1D 6 LD Bore N Stroke T (φ20 to φ100)
Cutting oil proof type 100SW-1D 6 LD Bore N Stroke T (φ32 to φ100)

None : Female thread type
T : Male thread type

• Bore φ20 and φ25

• Male thread type

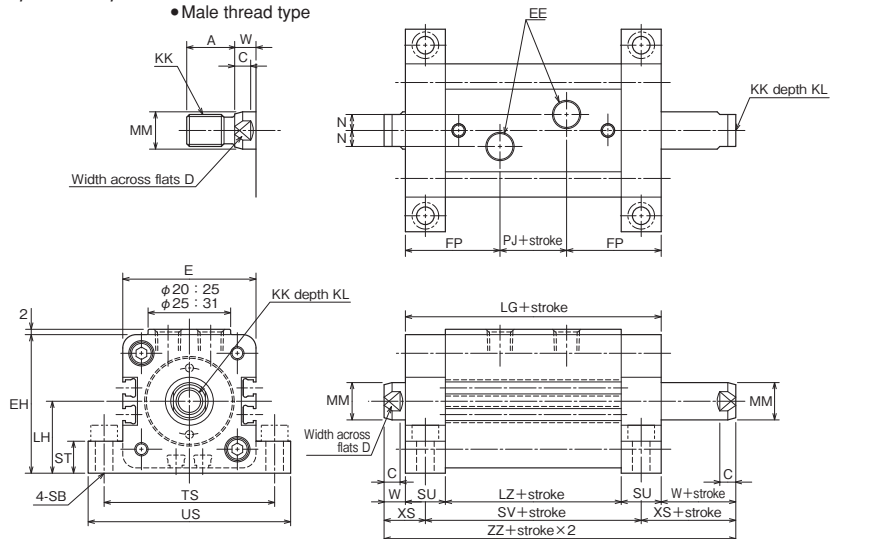

• Bore φ32 to φ100

• Male thread type

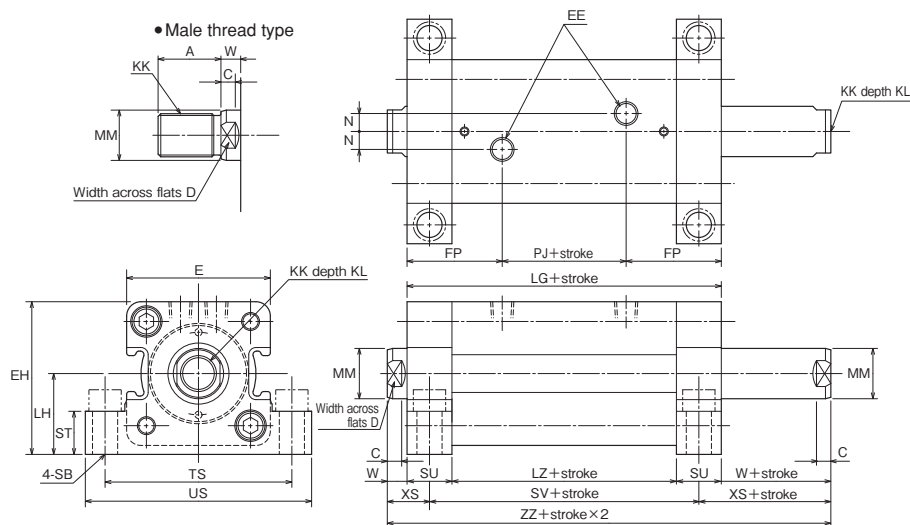

• For the mounting of sensors, refer to the "dimensional drawings of Switch Set".
All the contents other than sensor mounting dimensions are the same.
* When installing the cylinder on the grounding surface, be sure to use hex. socket head cap screws.

Dimensional Table

Symbol Bore	A	C	D	E	EE	EH	FP	KK		KL	LG	LH
								Female thread type	Male thread type			
φ20	15(25)	6	10	□44	Rc1/8	46	33.5	M8×1.25	M10×1.25	10	84	24±0.15
φ25	18(30)	6	12	□50	Rc1/8	52	35.5	M10×1.5	M12×1.25	12	86	27±0.15
φ32	25(40)	7	14	□62	Rc1/4	66	48	M12×1.75	M16×1.5	15	112	35±0.15
φ40	30(45)	7	19	□70	Rc1/4	72.5	47	M16×2	M20×1.5	20	112	37.5±0.15
φ50	35(50)	8	24	□80	Rc1/4	85	53	M20×2.5	M24×1.5	24	125	45±0.15
φ63	45(60)	9	30	□94	Rc1/4	97	55	M27×3	M30×1.5	33	132	50±0.15
φ80	60(80)	14	41	□114	Rc3/8	117	65	M30×3.5	M39×1.5	36	155	60±0.25
φ100	75(95)	22	50	□138	Rc3/8	140	77	M39×4	M48×1.5	45	178	71±0.25

Symbol Bore	LZ	MM	N	PJ	SB	ST	SU	SV	TS	US	W	XS	ZZ
φ20	54	φ12	3	17	6.6	12	15	69	58	70	8	15.5	100
φ25	56	φ14	6	15	6.6	12	15	71	64	76	8	15.5	102
φ32	72	φ18	10	16	9	16	20	92	79	94	10	20	132
φ40	72	φ22	10	18	11	20	20	92	90	108	10	20	132
φ50	75	φ28	10	19	14	24	25	100	104	126	11	23.5	147
φ63	82	φ36	10	22	16	30	25	107	121	146	13	25.5	158
φ80	95	φ45	15	25	18	35	30	125	144	172	17	32	189
φ100	108	φ56	15	24	22	43	35	143	174	208	26	43.5	230

(Notes) • When the lock nut is used, the parenthesized dimension A is recommended. (Order made)
• The lock nut needs to be ordered separately.
• 20 mm and 25 mm bore cylinders with a stroke of 5 mm have the same body size as those with a stroke of 10 mm.
• 20 mm and 25 mm bore sizes of the cutting oil proof type are not available.
• The tolerance of MM is f8.

CAD/DATA is available.

FA

General purpose type 100S-1D 6 FA Bore N Stroke T (φ20 to φ100)
Cutting oil proof type 100SW-1D 6 FA Bore N Stroke T (φ32 to φ100)

• Bore φ20 and φ25

• Male thread type

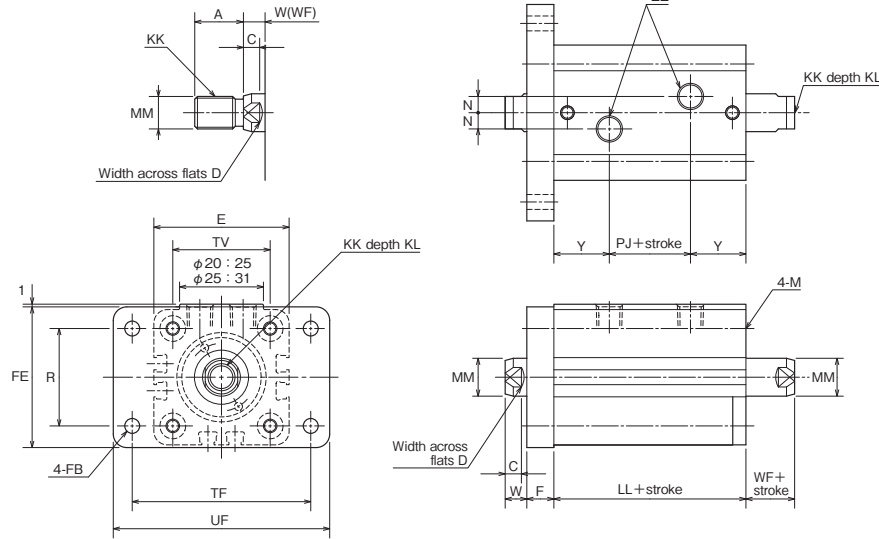

• Bore φ32 to φ100

• Male thread type

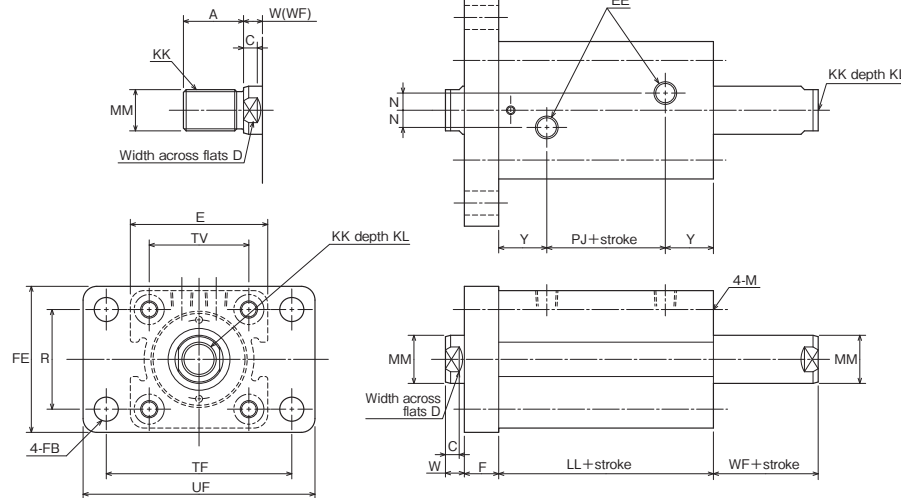

• For the mounting of sensors, refer to the "dimensional drawings of Switch Set". All the contents other than sensor mounting dimensions are the same.

Dimensional Table

Symbol Bore	A	C	D	E	EE	F	FB	FE	KK		KL	LL
									Female thread type	Male thread type		
φ20	15(25)	6	10	□44	Rc1/8	10	φ5.5	46	M8×1.25	M10×1.25	10	54
φ25	18(30)	6	12	□50	Rc1/8	10	φ5.5	52	M10×1.5	M12×1.25	12	56
φ32	25(40)	7	14	□62	Rc1/4	15	φ6.6	62	M12×1.75	M16×1.5	15	72
φ40	30(45)	7	19	□70	Rc1/4	20	φ11	70	M16×2	M20×1.5	20	72
φ50	35(50)	8	24	□80	Rc1/4	20	φ14	85	M20×2.5	M24×1.5	24	75
φ63	45(60)	9	30	□94	Rc1/4	20	φ14	98	M27×3	M30×1.5	33	82
φ80	60(80)	14	41	□114	Rc3/8	25	φ18	118	M30×3.5	M39×1.5	36	95
φ100	75(95)	22	50	□138	Rc3/8	30	φ22	150	M39×4	M48×1.5	45	108

Symbol Bore	M	MM	N	PJ	R	TF	TV	UF	W	WF	Y
φ20	M5×0.8	φ12	3	17	30	60	□30	75	8	8	18.5
φ25	M5×0.8	φ14	6	15	36	66	□36	80	8	8	20.5
φ32	M6×1	φ18	10	16	40	80	□47	95	10	10	28
φ40	M8×1.25	φ22	10	18	46	96	□52	118	10	10	27
φ50	M10×1.5	φ28	10	19	58	108	□58	135	11	11	28
φ63	M12×1.75	φ36	10	22	65	124	□69	150	13	13	30
φ80	M14×2	φ45	15	25	87	154	□86	185	17	17	35
φ100	M16×2	φ56	15	24	109	190	□106	230	26	26	42

- Notes) • When the lock nut is used, the parenthesized dimension A is recommended. (Order made)
 • The lock nut needs to be ordered separately.
 • 20 mm and 25 mm bore cylinders with a stroke of 5 mm have the same body size as those with a stroke of 10 mm.
 • 20 mm and 25 mm bore sizes of the cutting oil proof type are not available.
 • The tolerance of MM is f8.

Switch Set

General purpose type	100S-1R	6	Mounting style	Bore	N	Stroke	T	Sensor symbol	Sensor quantity
Cutting oil proof type	100SW-1R	6	Mounting style	Bore	N	Stroke	T	Sensor symbol	Sensor quantity

- Bore $\phi 20$ and $\phi 25$
Single rod

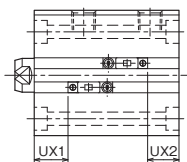
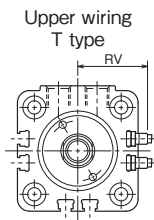
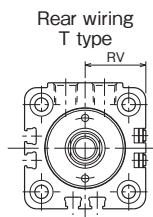

: Female thread type
 : Male thread type

Double rod

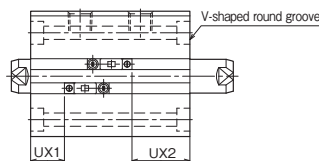
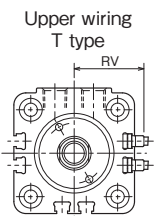
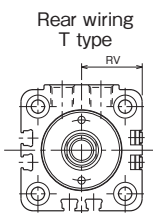

- The side without V-shaped round grooves on the end face corresponds to UX1.

- Bore $\phi 32$ to $\phi 100$
Single rod

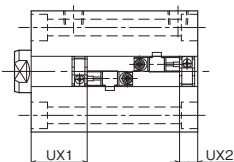
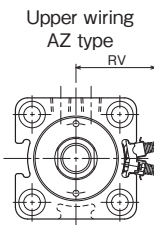
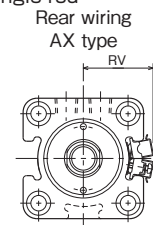

- The 100 mm bore cylinder has three sensor mounting grooves.

Double rod

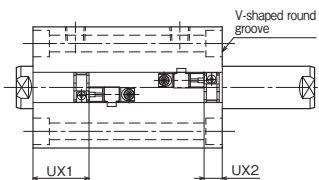
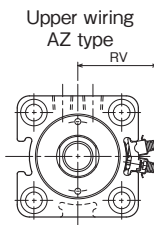
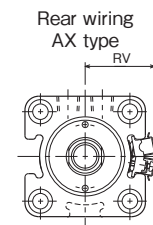

- The 100 mm bore cylinder has three sensor mounting grooves.
- The side without V-shaped round grooves on the end face corresponds to UX1.

General purpose type

Dimensional Table (T/AX/AZ type)

Bore	RV						UX1						UX2							
	T0H · T5H		T0V · T5V		T2YH	T2YV	AX	AZ	Single rod			Double rod			Single rod			Double rod		
	T2H · T3H	T2V · T3V	T	AX					AZ	T	AX	AZ	T	AX	AZ	T	AX	AZ		
$\phi 20$	22	26	28	31	-	-	13	-	-	13	-	-	12	-	-	23	-	-		
$\phi 25$	25	29	31	34	-	-	14	-	-	14	-	-	13	-	-	24	-	-		
$\phi 32$	-	-	-	-	37	44	-	19	19	-	19	19	-	17	17	-	35	35		
$\phi 40$	-	-	-	-	41	48	-	20	20	-	20	20	-	17	17	-	34	34		
$\phi 50$	-	-	-	-	46	53	-	22	22	-	22	22	-	20	20	-	35	35		
$\phi 63$	-	-	-	-	54	61	-	24	24	-	24	24	-	25	25	-	40	40		
$\phi 80$	-	-	-	-	63	70	-	30	30	-	30	30	-	30	30	-	47	47		
$\phi 100$	-	-	-	-	76.5	83.5	-	36	36	-	36	36	-	42	42	-	53	53		

Note) • Dimension UX is for reference only. For details, refer to the sensor mountable minimum stroke table.

Operating Range and Hysteresis

Bore	Reed sensor						Solid state sensor									
	AX1** · AZ1**		T type		WR type		AX2** · AZ2**		AX205W · AZ205W		T2/T3 type		T2Y type		WS type	
	Operating range	Hysteresis	Operating range	Hysteresis	Operating range	Hysteresis	Operating range	Hysteresis	Operating range	Hysteresis	Operating range	Hysteresis	Operating range	Hysteresis	Operating range	Hysteresis
$\phi 20$	-	-	3 to 10	2 or less	-	-	-	-	-	-	3 to 8	1 or less	5 to 10	1 or less	-	-
$\phi 25$	-	-	-	-	-	-	-	-	-	-	-	-	-	-	-	-
$\phi 32$	-	-	-	-	-	-	-	-	-	-	-	-	-	-	-	-
$\phi 40$	-	-	-	-	-	-	-	-	-	-	-	-	-	-	-	-
$\phi 50$	10 to 17	2 or less	-	-	10 to 17	2 or less	4 to 8	1 or less	15 to 22	2 or less	-	-	-	-	-	12 to 15
$\phi 63$	-	-	-	-	-	-	-	-	-	-	-	-	-	-	-	-
$\phi 80$	-	-	-	-	-	-	-	-	-	-	-	-	-	-	-	-
$\phi 100$	6 to 14	-	-	-	7 to 15	2.5 or less	6 to 9	-	19 to 25	-	-	-	-	-	-	19 to 25

Cutting oil proof type

Dimensional Table

Bore	RV				RY				UX1			UX2		
	Rear wiring		Upper wiring		Rear wiring		Upper wiring		AX*W	WR	WS	AX*W	WR	WS
	AX*W	WR · WS	AZ*W	WR · WS	AX*W	WR · WS	AZ*W	WR · WS	AX*W	WR	WS	AX*W	WR	WS
$\phi 32$	37	53	44	53	74	106	88	106	13(13)	11(11)	15(15)	11(29)	12(28)	16(32)
$\phi 40$	41	57	48	57	82	114	96	114	14(14)	17(17)	20(20)	11(28)	14(33)	16(36)
$\phi 50$	46	62	53	62	92	124	106	124	16(16)	19(19)	21(21)	14(29)	16(35)	20(37)
$\phi 63$	54	69	61	69	108	138	122	138	17(17)	20(20)	24(24)	18(33)	21(36)	23(40)
$\phi 80$	63	79	70	79	126	158	140	158	22(22)	25(25)	29(29)	22(39)	25(43)	29(47)
$\phi 100$	76.5	91.5	83.5	91.5	153	183	167	183	27(27)	33(33)	35(35)	33(44)	40(50)	41(52)

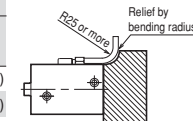

If the sensor cannot be mounted as shown above, use the upper wiring type.

- Notes) • Ensure that the bending radius of the flexible tube is R25 or more.
 If the bending radius is smaller, the wire may be broken.
 • The parenthesized values apply to the double rod cylinders.

Sensor Attachment Dimensions

• Rear wiring

AX205W(solid state sensor) WR525(reed sensor)
 WS235-1(solid state sensor)

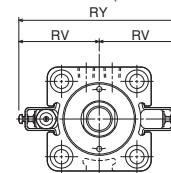
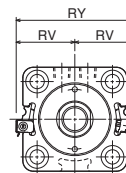

• Upper wiring

AZ205W(solid state sensor) WR535(reed sensor)
 WS245-1(solid state sensor)

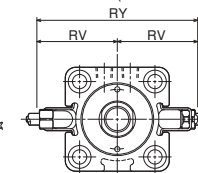
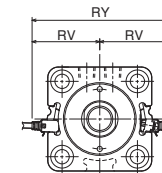

* The 100 mm bore cylinder has mounting grooves in three surfaces.

Change of Rod End Shape

■ You can specify the shape and dimension of the rod end as shown below using the semi-standard symbols and dimension symbols. (No need to specify the dimension symbol if you order a cylinder with the basic dimensions. Specify only the semi-standard symbol.)

How to order

Series Model number - X

Semi-standard symbol Dimension symbol (Specify only when the dimension differs from the basic dimension.)

KM and KP need to be specified as a pair. □

Example **A83**

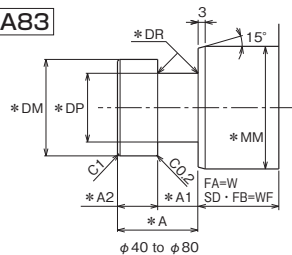

Note) In the case of this shape, only dimension WF can be changed.

- Bore $\phi 40$, rod end shape: A83, WF=60
- 100S-1 6SD40N50T-X A83
- WF=60

Special Rod End Shapes A00(T)

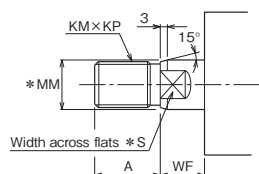

Table of Basic Dimensions (Standard dimensions)

Bore	A	KM	KP	*MM	*S	WF
$\phi 20$	15	10	1.25	$\phi 12$	10	8
$\phi 25$	18	12	1.25	$\phi 14$	12	8
$\phi 32$	25	16	1.5	$\phi 18$	14	10
$\phi 40$	30	20	1.5	$\phi 22$	19	10
$\phi 50$	35	24	1.5	$\phi 28$	24	11
$\phi 63$	45	30	1.5	$\phi 36$	30	13
$\phi 80$	60	39	1.5	$\phi 45$	41	17
$\phi 100$	75	48	1.5	$\phi 56$	50	26

A54

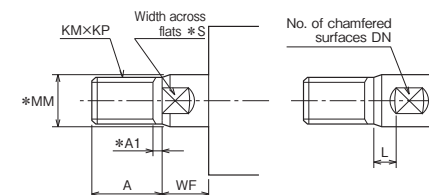

Table of Basic Dimensions

Bore	A	*A1	DN	KM	KP	L	*MM	*S	WF
$\phi 20$	15	4	2	10	1.25	0	$\phi 12$	10	8
$\phi 25$	18	4	2	12	1.25	0	$\phi 14$	12	8
$\phi 32$	25	4	2	16	1.5	0	$\phi 18$	14	10
$\phi 40$	30	4	2	20	1.5	0	$\phi 22$	19	10
$\phi 50$	35	4	2	24	1.5	0	$\phi 28$	24	11
$\phi 63$	45	4	2	30	1.5	0	$\phi 36$	30	13
$\phi 80$	60	4	2	39	1.5	0	$\phi 45$	41	17
$\phi 100$	75	4	2	48	1.5	0	$\phi 56$	50	26

A81

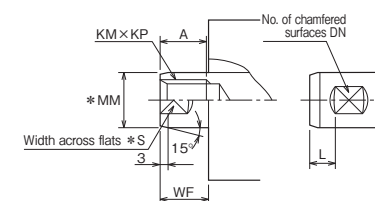

Table of Basic Dimensions

Bore	A	DN	KM	KP	L	*MM	*S	WF
$\phi 20$	10	2	8	1.25	0	$\phi 12$	10	8
$\phi 25$	12	2	10	1.5	0	$\phi 14$	12	8
$\phi 32$	15	2	12	1.75	0	$\phi 18$	14	10
$\phi 40$	20	2	16	2	0	$\phi 22$	19	10
$\phi 50$	24	2	20	2.5	0	$\phi 28$	24	11
$\phi 63$	33	2	27	3	0	$\phi 36$	30	13
$\phi 80$	36	2	30	3.5	0	$\phi 45$	41	17
$\phi 100$	45	2	39	4	0	$\phi 56$	50	26

A51

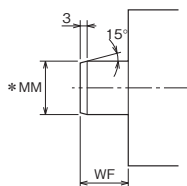
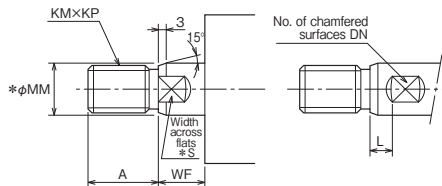

Table of Basic Dimensions

Bore	*MM	WF
$\phi 20$	$\phi 12$	8
$\phi 25$	$\phi 14$	8
$\phi 32$	$\phi 18$	10
$\phi 40$	$\phi 22$	10
$\phi 50$	$\phi 28$	11
$\phi 63$	$\phi 36$	13
$\phi 80$	$\phi 45$	17
$\phi 100$	$\phi 56$	26

A53



Note) Increase dimension WF by dimension L.

Table of Basic Dimensions

Bore	A	DN	KM	KP	L	*MM	*S	WF
$\phi 20$	15	2	10	1.25	0	$\phi 12$	10	8
$\phi 25$	18	2	12	1.25	0	$\phi 14$	12	8
$\phi 32$	25	2	16	1.5	0	$\phi 18$	14	10
$\phi 40$	30	2	20	1.5	0	$\phi 22$	19	10
$\phi 50$	35	2	24	1.5	0	$\phi 28$	24	11
$\phi 63$	45	2	30	1.5	0	$\phi 36$	30	13
$\phi 80$	60	2	39	1.5	0	$\phi 45$	41	17
$\phi 100$	75	2	48	1.5	0	$\phi 56$	50	26

Use this shape to move the width across flats S of 'A00(T)'.

A82

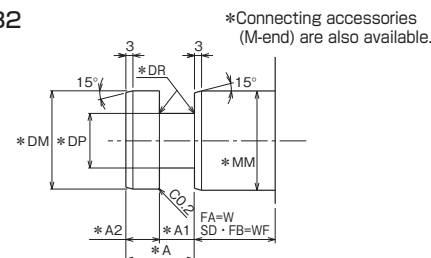

Table of Basic Dimensions (Standard dimensions)

Bore	*A	*A1	*A2	*DM	*DP	*DR	*MM	W	WF
		$+0.5$ -0.5	-0.2 -0.3		-0.2 -0.3			FA style	SD/FB style
$\phi 20$	25	12.5	12.5	$\phi 12$	$\phi 8$	0.5	$\phi 12$	20	20
$\phi 25$	25	12.5	12.5	$\phi 14$	$\phi 10$	0.5	$\phi 14$	20	20
$\phi 32$	25	12.5	12.5	$\phi 18$	$\phi 13$	1.0	$\phi 18$	30	30
$\phi 40$	25	12.5	12.5	$\phi 22$	$\phi 16$	1.5	$\phi 22$	35	35
$\phi 50$	25	12.5	12.5	$\phi 28$	$\phi 21$	1.5	$\phi 28$	35	35
$\phi 63$	30	15	15	$\phi 36$	$\phi 26$	2.0	$\phi 36$	40	40
$\phi 80$	30	15	15	$\phi 45$	$\phi 31$	2.0	$\phi 45$	45	45
$\phi 100$	40	20	20	$\phi 56$	$\phi 38$	3.0	$\phi 56$	55	55

A83

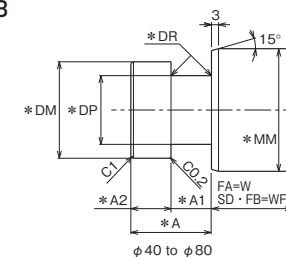

Table of Basic Dimensions (Standard dimensions)

Bore	*A	*A1	*A2	*DM	*DP	*DR	*MM	W	WF
		$+0.5$ -0.3	-0.2 -0.3	-0.1 -0.4	-0.2 -0.3			FA style	SD/FB style
$\phi 40$	25	12.5	12.5	$\phi 18$	$\phi 13$	1.0	$\phi 22$	35	35
$\phi 50$	25	12.5	12.5	$\phi 22$	$\phi 16$	1.5	$\phi 28$	35	35
$\phi 63$	25	12.5	12.5	$\phi 28$	$\phi 21$	1.5	$\phi 36$	40	40
$\phi 80$	30	15	15	$\phi 36$	$\phi 26$	2.0	$\phi 45$	45	45

- The *-marked dimension is fixed.
- If it is necessary to change the fixed dimension, consult us.

- The *-marked dimension is fixed.
- If it is necessary to change the fixed dimension, consult us.

Separate flange joint (M-end): Only for rod end shape A82

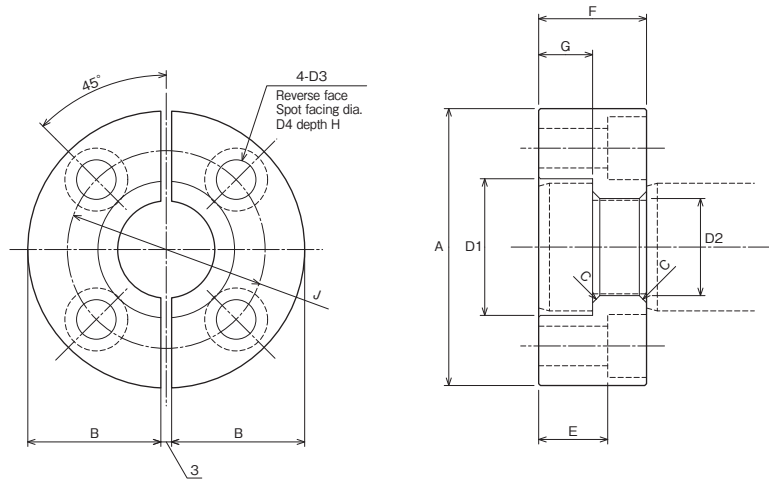

● Additional order must be made for this item. Specify as RMH-**.

Dimensional Table

Symbol Bore	Part number	A	B	C	D1	D2	D3	D4	E	F	G	H	J
φ20	RMH-12	φ44	20.5	0.5	φ13	φ8.5	φ5.5	φ9.5	19.6	25	12.5	5.4	φ29
φ25	RMH-14	φ46	21.5	0.5	φ15	φ10.5	φ5.5	φ9.5	19.6	25	12.5	5.4	φ31
φ32	RMH-18	φ49	23	1	φ19	φ13.5	φ6.6	φ11	18.5	25	12.5	6.5	φ34
φ40	RMH-22	φ57	27	1.5	φ23	φ16.5	φ9	φ14	16.4	25	12.5	8.6	φ40
φ50	RMH-28	φ71	34	1.5	φ29	φ21.5	φ11	φ17.5	14.2	25	12.5	10.8	φ50
φ63	RMH-36	φ77	37	2	φ38	φ27	φ11	φ17.5	19.2	30	15	10.8	φ55
φ80	RMH-45	φ100	48.5	2	φ48	φ33	φ14	φ20	17	30	15	13	φ76
φ100	RMH-56	φ124	60.5	3	φ60	φ41	φ18	φ26	22.5	40	20	17.5	φ92

Setting method of sensor detecting position

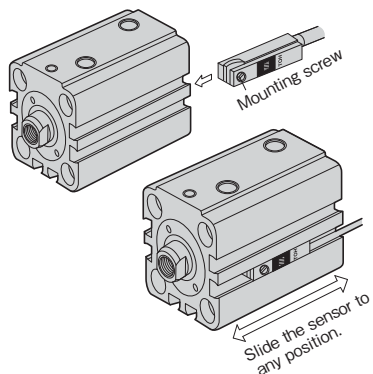
T type sensor ($\phi 20$ and $\phi 25$)

1. Fit the sensor into the groove as shown left.
2. Slide the sensor to any position. Installing in the center of operating range provides the most stable detection.
3. To detect the cylinder stroke end, mount the sensor at dimension UX (optimum setting position).
4. After sliding the sensor to the detecting position, tighten the mounting screw.

Torque of Mounting Screw

Sensor type	T0-T5-T2-T3	T2Y
Nominal dia. of mounting screw	M2.5	M3
Mounting screw tightening tool	Precision slotted screwdriver	Small-sized Phillips-head screwdriver
Tightening torque	Approx. 0.1 to 0.2 N·m	Approx. 0.4 N·m

Note) If the tightening torque is improper, the sensor may be dislocated, or the sensor body may be damaged.

AX/AZ type sensor ($\phi 32$ to $\phi 100$)

AX/AZ type bracket screw tightening torque :
Approx. 0.4 N·m

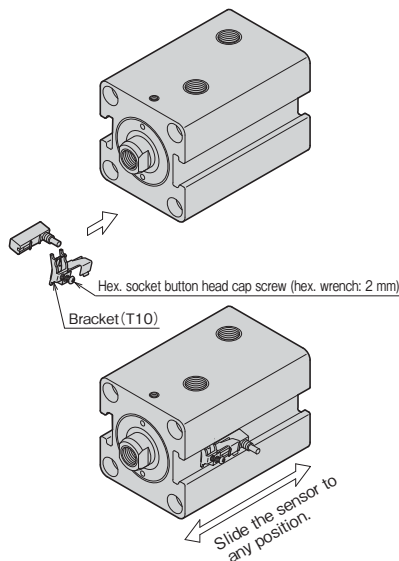
WR/WS type sensor ($\phi 32$ to $\phi 100$)

WR/WS type bracket screw tightening torque :
Approx 0.6 N·m

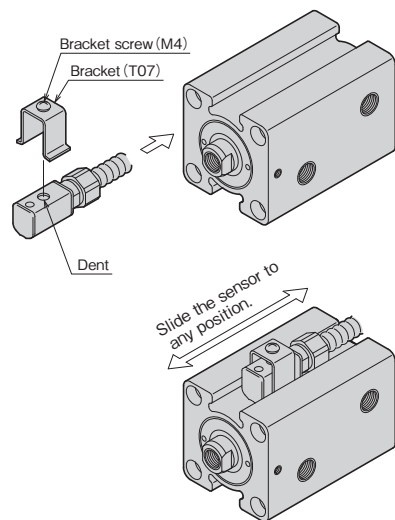

1. Loosen the bracket screw, and fit the bracket in the center of the sensor.
2. Insert the sensor combined with the bracket into the sensor mounting part of the cylinder body.
3. Slide the sensor to any position. Installing in the center of operating range provides the most stable detection.
4. To detect the cylinder stroke end, mount the sensor at dimension UX (optimum setting position).
5. After sliding the sensor to the detecting position, tighten the bracket screw.

Note) If the tightening torque is improper, the sensor may be dislocated, or the sensor body may be damaged.

Precautions for use

- When using the cylinder with stroke adjuster tighten the screw(s) to the rod end completely so that no load is applied to the piston rod screw section.
- Since side load (eccentric load) must not be applied to the piston rod, take care when installing the cylinder.
- When operating the cylinder for the first time, discharge air from the piping. After discharging air, run the cylinder at a reduced pressure, and gradually increase the pressure to the working pressure.
Note) Since 100S-1 Series has no air vents, take air bleeding from the piping.
- To install the cylinder, use four hex. socket head cap screws (JIS B1176, strength class 10.9 or more).
- When using mounting bolts, screw the bolts into mounting materials by 80% or more of the screw diameter. The material of the mounting materials must have strength equal to SS400.
- When using nuts to tighten mounting bolts, use steel nuts with a strength class of 6 or more. (However, DO NOT use the type-3 nuts.)
- When using mounting bolts to secure the cylinder body, be sure to tighten them according to the following specified torque.

Cylinder Mounting Bolt Tightening Torque

Cylinder bore	Mounting bolt size	Tightening torque
$\phi 20$	M5×0.8	4.8
$\phi 25$	M5×0.8	4.8
$\phi 32$	M6×1	5.9
$\phi 40$	M8×1.25	14.0
$\phi 50$	M10×1.5	28.0
$\phi 63$	M12×1.75	49.0
$\phi 80$	M14×2	77.0
$\phi 100$	M16×2	120.0

- When tightening the piston rod end screw of a double acting double rod cylinder, use the width across flats on the side on which the screw is tightened. Since the piston rod of a double rod type cylinder is fastened with screws, take care that rotating force at both ends of the piston rod is not applied to the rod.

Notes on disassembly and reassembly

- After removing the set screw, use the turning hole of the bush to remove the bush from the cylinder. When a jig is removed from the rod end screw, burrs may occur on the width across flats of the rod. Remove the burrs with a file, etc. and remove the bush.

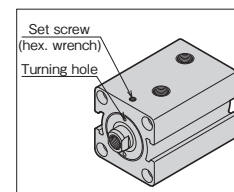

Note) A copper piece may have been set under the set screw.

- The piston rod and piston cannot be disassembled.
- When reassembling the cylinder, be careful that foreign matters such as dust, fillings, and debris do not enter the inside of the cylinder.

- When a copper piece is equipped under the set screw to protect the bush, remove it before tightening the bush.
- The center height of cylinders of the mounting style LD has been determined before shipment. When reassembling such a cylinder, adjust the center height.
- After tightening the bush:
In case of ①, place the copper piece under the set screw and tighten it.
In case of ②, tighten the set screw without placing the copper piece.

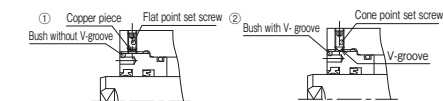

Components Combination List

No.	Screw on bush	Copper piece	Set screw type
①	Without V-groove	Required	Flat point
②	With V-groove	—	Cone point

Seal replacement

- When disassembling the cylinder, replace all seals.
- General purpose types (100S-1, 100S-1D, 100S-1R and 100S-1RD): The piston seals, rod seals, dust wipers and bush O-rings are replaceable.
- Cutting oil proof types (100SW-1, 100SW-1D, 100SW-1R and 100SW-1RD): The piston seals, rod seals and bush O-rings are replaceable. The dust wiper 1 of any cutting oil proof type cylinder has been press-fitted into the bush, and is integrated with the bush. Although it can be removed, doing so may damage the bush. It is recommended to replace the bush as well when replacing the dust wiper. The dust wiper 1 is not included in the seal set. If it is necessary, separately make an order.
- Since the piston and rod have been locked, the piston rod O-ring cannot be replaced.
- Dimensions of bush turning hole

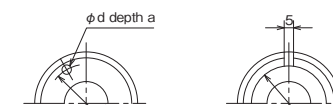

* General purpose type: Bore $\phi 20$ to $\phi 100$ * Cutting oil proof type: Bore $\phi 40$ to $\phi 100$

Unit : mm

Bore	a	d	PCD	Bore	a	d	PCD
$\phi 20$	4	4	23	$\phi 50$	8	5	46
$\phi 25$	4	4	25	$\phi 63$	8	5	58
$\phi 32$	5	4	32	$\phi 80$	10	8	70
$\phi 40$	7	4	38	$\phi 100$	12	10	85

Interpretation of usable range

1) 100S-1 Series has product life expectancy of 10 million times or more at the rated pressure of 10 MPa.

2) How to determine the working pressure range

- The fatigue life is determined by the results of fatigue test of actual cylinder and the values obtained by statistically processing the test data.
- The life distribution is determined from the data of the fatigue test of actual cylinders, and the working pressure range is obtained based on the values with a failure probability of 1% in the distribution.

Note) No point of 0% exists in terms of statistical technique.

3) The working pressure is the pressure generated in a cylinder.

- The working pressure is not the set pressure of the relief valve.
- In the cylinder, a pressure higher than the set pressure of the relief valve can be generated due to surge pressure caused by valve switching.
- Design the hydraulic circuit so that surge pressure hardly occurs.

